

Cam switch in enclosure ŁK15 OB3

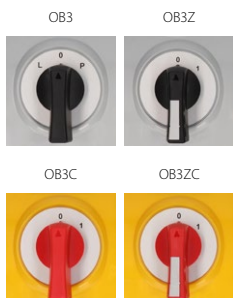

Ordering code

ŁK15- \

Mounting method

- OB3** in housing OB3
- OB3C** in housing OB3 with yellow-red front
- OB3Z** in housing OB3 with lockable front
- OB3ZC** in housing OB3 with lockable yellow-red front

Assembly number

- 1.825** Disconnecter 0-1 (1 - pole)
- 1.828** Disconnecter 0-1 (2 - pole)
- 2.8211** Disconnecter 0-1 (3 - pole)
- 2.8210** Disconnecter 0-1 (4 - pole)
- 3.8220** Disconnecter 0-1 (5 - pole)
- 3.8210** Disconnecter 0-1 (6 - pole)
- 4.8240** Disconnecter 0-1 (7 - pole)
- 4.824** Disconnecter 0-1 (8 - pole)
- 5.8220** Disconnecter 0-1 (9 - pole)
- 5.822** Disconnecter 0-1 (10 - pole)
- 6.8210** Disconnecter 0-1 (11 - pole)
- 6.821** Disconnecter 0-1 (12 - pole)
- 3.8368** Reversing switch L-0-P
- 3.83139** 2-speed switch
2 separate windings
- 4.8390** 2-speed Dahlander switch
- 4.831** 3-phase starting switch 0-Y-Δ
- 5.8538** 3-phase starting
reversing switch
- 4.883** Voltmeter selector switch
- 2.4414** Rotary disconnecter 0-1
- 2.8445** Control switch 0-1-2-3
- 1.834** Disconnecter 1-0-2 (1 - pole)
- 2.8338** Disconnecter 1-0-2 (2 - pole)
- 3.8380** Disconnecter 1-0-2 (3 - pole)
- 4.8396** Disconnecter 1-0-2 (4 - pole)
- 5.8380** Disconnecter 1-0-2 (5 - pole)
- 6.8380** Disconnecter 1-0-2 (6 - pole)

Dimensions

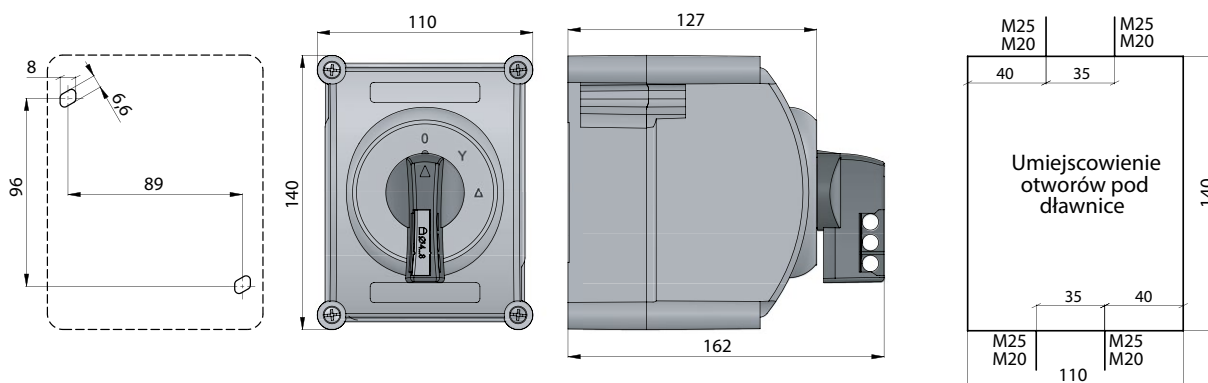

Number of segments in the switch

1 ... 6

Gland type

M25x1,5

Note!

For assembly ŁK15-4.831 and ŁK15-3.8368
3 glands M25x1,5 are used

Technical data (continuous work)

Rated insulation voltage U_i	500 V
Rated withstand impulse voltage U_{imp}	4 kV
Rated continuous current $I_u=I_{th}$	16 A
Rated operational current I_e for AC-15	7 A (500 V)
Rated operational current I_e for AC-3	8.7 A (400 V) 8.7 A (500 V)
Rated operational current I_e for AC-4	7 A (400 V) 7 A (500 V)
Short-time short-circuit withstand current $I_{cw}(1s)$	0.5 kA
Rated short-circuit making current I_{cm}	2 kA
Tightening torque, terminals	1.2 Nm
Mechanical endurance	3.0 mln (transposition cycles)
Ambient temperature	-25 ... +70°C (work) -25 ... +70°C (storage)
Wire gauge	1.5...4 mm ²
Protection level: PN-EN 60529 to the panel	IP41 IP65