

Cam switch in enclosure ŁK25R OB2

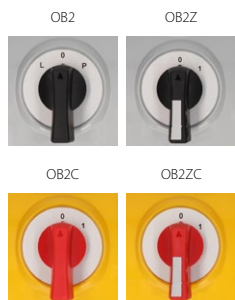

Ordering code

ŁK 25 R- \

Mounting method

- OB2** in housing OB2
- OB2C** in housing OB2 with yellow-red front
- OB2Z** in housing OB2 with lockable front
- OB2ZC** in housing OB2 with lockable yellow-red front

Assembly number

- 1.825** Disconnecter 0-1 (1 - pole)
- 1.828** Disconnecter 0-1 (2 - pole)
- 2.8211** Disconnecter 0-1 (3 - pole)
- 2.8210** Disconnecter 0-1 (4 - pole)
- 3.8220** Disconnecter 0-1 (5 - pole)
- 3.8210** Disconnecter 0-1 (6 - pole)
- 4.8240** Disconnecter 0-1 (7 - pole)
- 4.824** Disconnecter 0-1 (8 - pole)
- 3.8368** Reversing switch L-0-P
- 3.83139** 2-speed switch
- 2 separate windings
- 4.8390** 2-speed Dahlander switch
- 4.831** 3-phase starting switch 0-Y-Δ
- 4.883** Voltmeter selector switch
- 2.4414** Rotary disconnecter 0-1
- 2.8445** Control switch 0-1-2-3
- 1.834** Disconnecter 1-0-2 (1 - pole)
- 2.8338** Disconnecter 1-0-2 (2 - pole)
- 3.8380** Disconnecter 1-0-2 (3 - pole)
- 4.8396** Disconnecter 1-0-2 (4 - pole)

Current
25 25 A

Dimensions

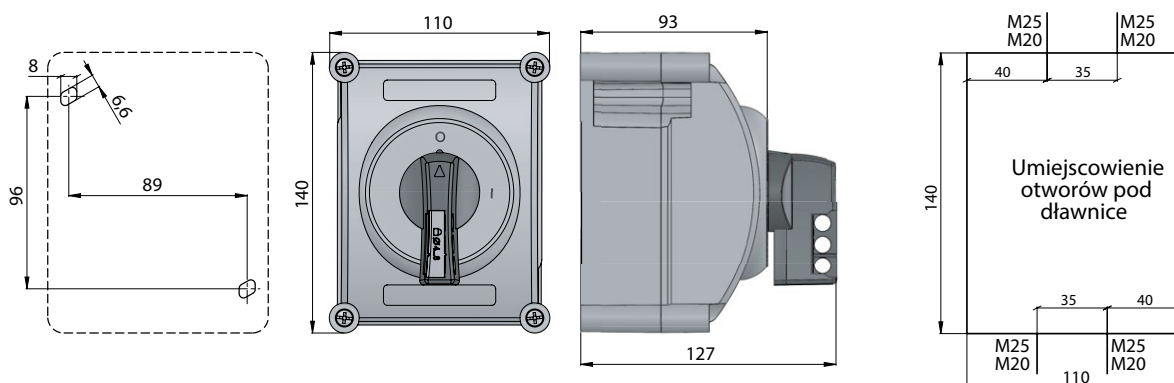

Number of segments in the switch

1 ... 4

Gland type

M25x1,5

Note!

For assembly ŁK25R-4.831 and ŁK25R-3.8368
3 glands M25x1,5 are used

Technical data (continuous work)

Rated insulation voltage U_i	690 V
Rated withstand impulse voltage U_{imp}	6 kV
Rated continuous current $I_u=I_{th}$	25 A
Rated operational power P_e for AC-3	7 kW (230 V) 13 kW (400 V) 10 kW (690 V)
Rated operational power P_e for AC-4	6 kW (230 V) 8 kW (400 V) 7 kW (690 V)
Rated operational current I_e for AC-3	25 A (230 V) 25 A (400 V) 14 A (690 V)
Rated operational current I_e for AC-4	20 A (230 V) 16 A (400 V) 8 A (690 V)
Rated operational current I_e for DC-21	12 A (110 V) 3 A (220 V)
Short-time short-circuit withstand current $I_{cw}(1s)$	1 kA
Rated short-circuit making current I_{cm}	1.4 kA
Rated conventional short-circuit current	13 kA
Rated current fuse link gG	25 A
Tightening torque, terminals	1.2 Nm
Mechanical endurance	3.0 mln (transposition cycles)
Ambient temperature	-40 ... +70°C (work) -40 ... +70°C (storage)
Wire gauge	2.5...6 mm ²
Protection level: PN-EN 60529 to the panel	IP65
Vibration test (acc. to IEC 60068-2-6)	2...13, 2...100 Hz (frequency) ± 1 mm (acceleration amplitude) ±0.7 g (acceleration amplitude)
Shock test (acc. to IEC 60068-2-27)	15 g (peak acceleration) 11 ms (impulse duration)
Damp heat cyclic test (acc. to IEC 60068-2-30)	55°C (ambient temperature) 95% (relative humidity)
Salt mist cyclic test (acc. to IEC 60068-2-52)	severity 1