

## Cam switch in enclosure ŁK63 OB4



### Ordering code

ŁK 63 -  \

#### Mounting

- OB4** in housing OB4
- OB4C** in housing OB4 with yellow-red front
- OB4Z** in housing OB4 with lockable front
- OB4ZC** in housing OB4 with lockable yellow-red front

#### Assembly number

- 1.825** Disconnecter 0-1 (1 - pole)
- 1.828** Disconnecter 0-1 (2 - pole)
- 2.8211** Disconnecter 0-1 (3 - pole)
- 2.8210** Disconnecter 0-1 (4 - pole)
- 3.8220** Disconnecter 0-1 (5 - pole)
- 3.8210** Disconnecter 0-1 (6 - pole)
- 3.8368** Reversing switch L-0-P
- 3.83139** 2-speed switch  
2 separate windings
- 2.4414** Rotary disconnecter 0-1
- 2.8445** Control switch 0-1-2-3
- 1.834** Disconnecter 1-0-2 (1 - pole)
- 2.8338** Disconnecter 1-0-2 (2 - pole)
- 3.8380** Disconnecter 1-0-2 (3 - pole)

#### Current

63 63 A

### Dimensions

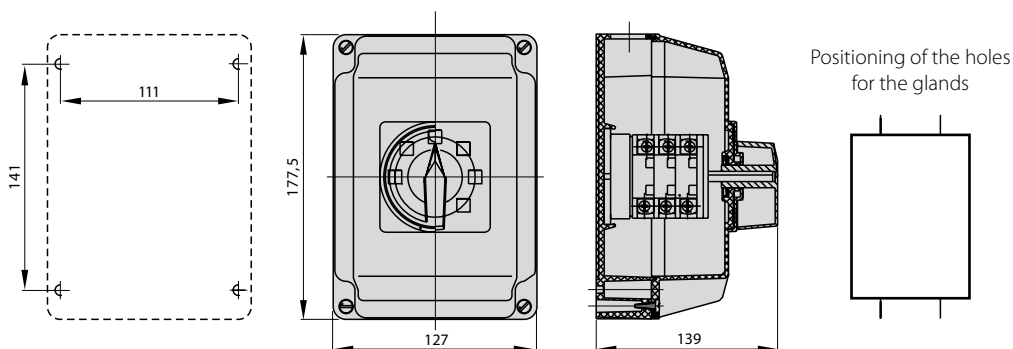

### Number of segments in the switch

1 ... 3

### Gland type

M32x1,5

#### Note!

For assembly ŁK63-3.8368  
3 glands M25x1,5 are used

## Technical data (continuous work)

Rated insulation voltage $U_i$	690 V
Rated withstand impulse voltage $U_{imp}$	6 kV
Rated continuous current $I_u=I_{th}$	63 A
Rated operational power $P_e$ for AC-3	20 kW (400 V) 20 kW (500 V) 10 kW (690 V)
Rated operational power $P_e$ for AC-4	12 kW (400 V) 8 kW (690 V)
Rated operational current $I_e$ for AC-3	38 A (400 V) 30 A (500 V) 11 A (690 V)
Rated operational current $I_e$ for AC-4	23 A (400 V) 8.5 A (690 V)
Short-time short-circuit withstand current $I_{cw}(1s)$	1.2 kA
Rated short-circuit making current $I_{cm}$	2.2 kA
Tightening torque, terminals	2.0 Nm
Mechanical endurance	3.0 mln (transposition cycles)
Ambient temperature	-40 ... +70°C (work) -40 ... +70°C (storage)
Wire gauge	4...10 mm <sup>2</sup>
Protection level: PN-EN 60529 to the panel	IP41 IP65
Vibration test (acc. to IEC 60068-2-6)	2...13, 2...100 Hz (frequency) ± 1 mm (acceleration amplitude) ±0.7 g (acceleration amplitude)
Shock test (acc. to IEC 60068-2-27)	15 g (peak acceleration) 11 ms (impulse duration)
Damp heat cyclic test (acc. to IEC 60068-2-30)	55°C (ambient temperature) 95% (relative humidity)
Salt mist cyclic test (acc. to IEC 60068-2-52)	severity 1