

## Cam switch in enclosure SK100 OB18



### Ordering code

SK 100 -  \

#### Mounting

- OB18** in housing OB18, legend plate, black knob
- OB18C** in housing OB18, yellow legend plate, red knob
- OB18Z** in housing OB18, legend plate, black knob, lockable
- OB18ZC** in housing OB18, yellow legend plate, red knob, lockable

#### Assembly number

- 1.825** Disconnector 0-1 (1 - pole)
- 1.828** Disconnector 0-1 (2 - pole)
- 2.8211** Disconnector 0-1 (3 - pole)
- 2.8210** Disconnector 0-1 (4 - pole)
- 3.8220** Disconnector 0-1 (5 - pole)
- 3.8210** Disconnector 0-1 (6 - pole)
- 4.8240** Disconnector 0-1 (7 - pole)
- 4.824** Disconnector 0-1 (8 - pole)
- 3.8368** Reversing switch L-0-P
- 3.83139** 2-speed switch  
2 separate windings
- 4.8390** 2-speed Dahlander switch
- 4.831** 3-phase starting switch 0-Y-Δ
- 4.883** Voltmeter selector switch
- 2.4414** Rotary disconnector 0-1
- 2.8445** Control switch 0-1-2-3
- 1.834** Disconnector 1-0-2 (1 - pole)
- 2.8338** Disconnector 1-0-2 (2 - pole)
- 3.8380** Disconnector 1-0-2 (3 - pole)
- 4.8396** Disconnector 1-0-2 (4 - pole)

#### Current

100 100 A

### Dimensions

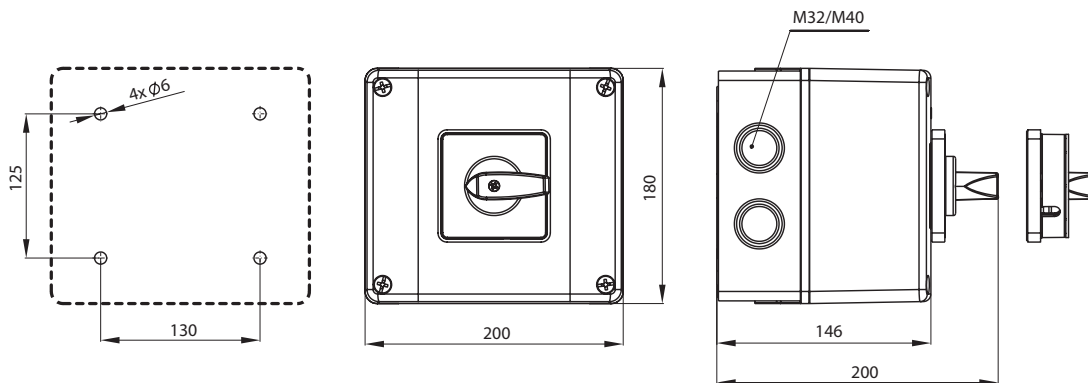

### Number of segments in the switch

1 ... 4

### Gland type

M32/40

## Technical data

Rated insulation voltage $U_e$	690 V
Rated withstand impulse voltage $U_{imp}$	6 kV
Rated continuous current $I_u$	100 A
Rated operational current $I_c$	100 A
Conventional rated thermal current in the air $I_{th}$	100 A
Conventional rated thermal current in the enclosure $I_{the}$	100 A
Frequency	50/60 Hz
Rated operational current $I_e$ for AC-21A, AC-22A	100 A (230/400/500/690 V)
Rated operational power $P_e$ for AC-23A	18 kW (230 V) 31 kW (400 V) 38 kW (500 V) 50 kW (690 V)
Rated operational power $P_e$ for AC-3	18 kW (230 V) 25 kW (400 V) 30 kW (500 V) 38 kW (690 V)
Switching angle	45°-90°
Short-time short-circuit withstand current $I_{cw}(1s)$	1.7 kA
Rated short-circuit making current $I_{cm}$	2.5 kA
Wire gauge	16...35 mm <sup>2</sup> (solid) 16...25 mm <sup>2</sup> (stranded)
Panel mounting	□68
Screws in the terminals	M6
Tightening torque, wires (hold down)	4.4 Nm
Mechanical endurance	3.0 mln (transposition cycles)
Ambient temperature	-40 ... +70°C (work) -40 ... +70°C (storage)
Protection level: PN-EN 60529 to the panel	IP65
Protection level of OB enclosure	IP65
Protection level of the terminals	IP20
Pollution degree EN 60947-1	3
Protection class in OB housing	II
Vibration test (acc. to IEC 60068-2-6)	2...100 Hz (frequency) 13.2 Hz (frequency) ± 1 mm (acceleration amplitude) ±0.7 g (acceleration amplitude)
Shock test (acc. to IEC 60068-2-27)	15 g (peak acceleration) 11 ms (impulse duration)
Damp heat cyclic test (acc. to IEC 60068-2-30)	55°C (ambient temperature) 95% (relative humidity)
Salt mist cyclic test (acc. to IEC 60068-2-52)	severity 1