

Cam switch, panel-mounted, SK16G P



### Ordering code

SK 16 G-  \

#### Mounting

- P23** front I (IP65), mounting with 2 screws
- P03** front I (IP65), mounting with 4 tapping screws
- P24** front I yellow-red (IP65), mounting with 2 screws
- P04** front I yellow-red (IP65), mounting with 4 tapping screws
- P27** front III (IP65), lockable, mounting with 2 screws
- P07** front III (IP65), lockable, mounting with 4 tapping screws
- P28** front III (IP65), lockable, mounting with 2 screws
- P08** front III yellow-red (IP65), lockable, mounting with 4 tapping screws

#### Assembly number

- 1.825** Disconnecter 0-1 (1 - pole)
- 1.828** Disconnecter 0-1 (2 - pole)
- 2.8211** Disconnecter 0-1 (3 - pole)
- 2.8210** Disconnecter 0-1 (4 - pole)
- 3.8220** Disconnecter 0-1 (5 - pole)
- 3.8210** Disconnecter 0-1 (6 - pole)
- 4.8240** Disconnecter 0-1 (7 - pole)
- 4.824** Disconnecter 0-1 (8 - pole)
- 5.8220** Disconnecter 0-1 (9 - pole)
- 5.822** Disconnecter 0-1 (10 - pole)
- 6.8210** Disconnecter 0-1 (11 - pole)
- 6.821** Disconnecter 0-1 (12 - pole)
- 7.8220** Disconnecter 0-1 (13 - pole)
- 7.822** Disconnecter 0-1 (14 - pole)
- 8.8270** Disconnecter 0-1 (15 - pole)
- 8.827** Disconnecter 0-1 (16 - pole)
- 9.8210** Disconnecter 0-1 (17 - pole)
- 9.821** Disconnecter 0-1 (18 - pole)
- 10.8210** Disconnecter 0-1 (19 - pole)
- 10.821** Disconnecter 0-1 (20 - pole)
- 3.8368** Reversing switch L-0-P
- 3.83139** 2-speed switch  
2 separate windings
- 4.8390** 2-speed Dahlander switch
- 7.8538** 2-speed reversing  
Dahlander switch
- 4.831** 3-phase starting switch 0-Y-Δ
- 5.8538** 3-phase starting  
reversing switch
- 6.4470** 3-speed Dahlander switch  
single winding for low speed
- 6.4480** 3-speed Dahlander switch  
single winding for medium speed
- 6.4490** 3-speed Dahlander switch  
single winding for high speed
- 4.883** Voltmeter selector switch
- 2.4414** Rotary disconnecter 0-1
- 2.8445** Control switch 0-1-2-3
- 1.834** Disconnecter 1-0-2 (1 - pole)
- 2.8338** Disconnecter 1-0-2 (2 - pole)
- 3.8380** Disconnecter 1-0-2 (3 - pole)
- 4.8396** Disconnecter 1-0-2 (4 - pole)
- 5.8380** Disconnecter 1-0-2 (5 - pole)
- 6.8380** Disconnecter 1-0-2 (6 - pole)
- 7.8380** Disconnecter 1-0-2 (7 - pole)
- 8.8380** Disconnecter 1-0-2 (8 - pole)
- 9.8380** Disconnecter 1-0-2 (9 - pole)
- 10.8380** Disconnecter 1-0-2 (10 - pole)

16 Current  
16 A

### Components

#### Fronts of cam switches

Front I SK10-1406 for assemblies P... and BS...

Front I SK10-1406 for assemblies P...

Front III SK10-1410 for assemblies P... and BS...(lockable)

Front III SK10-1410 for assemblies P...(lockable)

### Dimensions

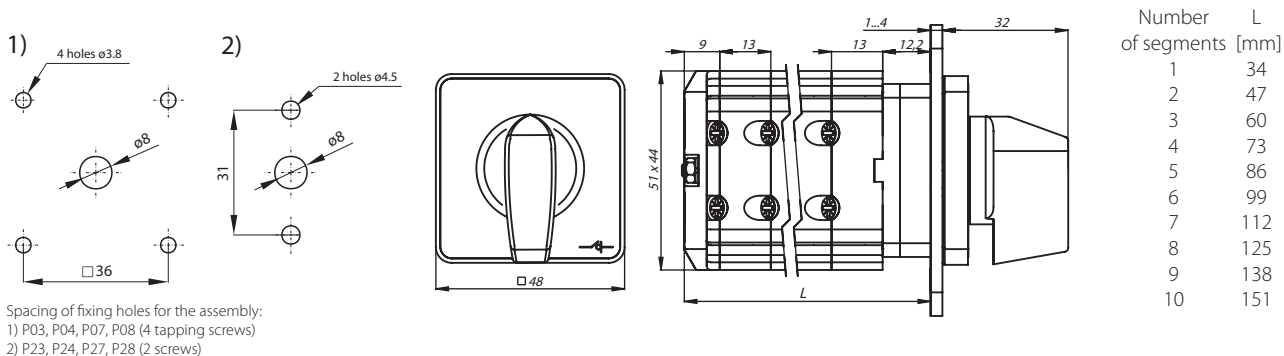

Spacing of fixing holes for the assembly:  
 1) P03, P04, P07, P08 (4 tapping screws)  
 2) P23, P24, P27, P28 (2 screws)

### Number of segments in the switch

1 ... 10

### Technical data

Rated insulation voltage $U_e$	690 V
Rated withstand impulse voltage $U_{imp}$	6 kV
Rated continuous current $I_U=I_{th}$	20 A
Rated operational current $I_e$ for AC-21A, AC-22A	16 A (230/400/500/690 V)
Rated operational power $P_e$ for AC-23A	3 kW (230 V) 5 kW (400 V) 6 kW (500 V) 8 kW (690 V)
Rated operational power $P_e$ for AC-3	2 kW (230 V) 3.5 kW (400 V) 4 kW (500 V) 6 kW (690 V)
Rated operational current $I_e$ for DC-21A	16 A (24 V) 8 A (110 V) 6 A (220 V)
Short-time short-circuit withstand current $I_{cw}(1s)$	0.5 kA
Rated short-circuit making current $I_{cm}$	0.7 kA
Rated conventional short-circuit current	10 kA
Rated current fuse link gG	16 A
Wire gauge	1.0...2.5 mm <sup>2</sup> (sztywnych, giętkich)
Tightening torque, terminals	max 0,8 Nm
Panel mounting	31/□36
Mechanical endurance	3.0 mIn (transposition cycles)