

Cam switch, base-rail mounted, SK63 BS



Ordering code

SK 63 - \

Mounting

- BS03** base-rail mounted, legend plate, black knob
- BS04** base-rail mounted, yellow legend plate, red knob
- BS07** base-rail mounted, legend plate, black knob, lockable
- BS08** base-rail mounted, yellow legend plate, red knob, lockable

Assembly number

- 1.825** Disconnecter 0-1 (1 - pole)
- 1.828** Disconnecter 0-1 (2 - pole)
- 2.8211** Disconnecter 0-1 (3 - pole)
- 2.8210** Disconnecter 0-1 (4 - pole)
- 3.8220** Disconnecter 0-1 (5 - pole)
- 3.8210** Disconnecter 0-1 (6 - pole)
- 4.8240** Disconnecter 0-1 (7 - pole)
- 4.824** Disconnecter 0-1 (8 - pole)
- 5.8220** Disconnecter 0-1 (9 - pole)
- 5.822** Disconnecter 0-1 (10 - pole)
- 6.8210** Disconnecter 0-1 (11 - pole)
- 6.821** Disconnecter 0-1 (12 - pole)
- 7.8220** Disconnecter 0-1 (13 - pole)
- 7.822** Disconnecter 0-1 (14 - pole)
- 3.8368** Reversing switch L-O-P
- 3.83139** 2-speed switch
2 separate windings
- 4.8390** 2-speed Dahlander switch
- 7.8538** 2-speed reversing
Dahlander switch
- 4.831** 3-phase starting switch 0-Y-Δ
- 5.8538** 3-phase starting
reversing switch
- 6.4470** 3-speed Dahlander switch
single winding for low speed
- 6.4480** 3-speed Dahlander switch
single winding for medium speed
- 6.4490** 3-speed Dahlander switch
single winding for high speed
- 4.883** Voltmeter selector switch
- 2.4414** Rotary disconnecter 0-1
- 2.8445** Control switch 0-1-2-3
- 1.834** Disconnecter 1-0-2 (1 - pole)
- 2.8338** Disconnecter 1-0-2 (2 - pole)
- 3.8380** Disconnecter 1-0-2 (3 - pole)
- 4.8396** Disconnecter 1-0-2 (4 - pole)
- 5.8380** Disconnecter 1-0-2 (5 - pole)
- 6.8380** Disconnecter 1-0-2 (6 - pole)
- 7.8380** Disconnecter 1-0-2 (7 - pole)

Current

63 63 A

It is recommended that TS35 rail, on which the switch will be mounted, is installed on supports (not directly on the base).

Components

Fronts of cam switches

Front I SK63-1406 for assemblies P... and BS...

Front I SK63-1406 for assemblies BS... (mounted directly on the door)

Front III SK63-1409 for assemblies P... and BS... (padlockable)

Front III SK63-1409 for assemblies BS... (padlockable, mounted directly on the door)

Dimensions

Snap mounting on TS35 rail

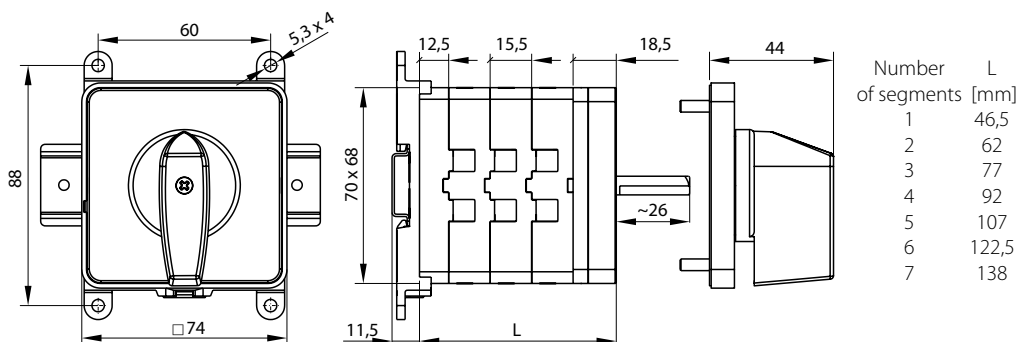

Base mounting

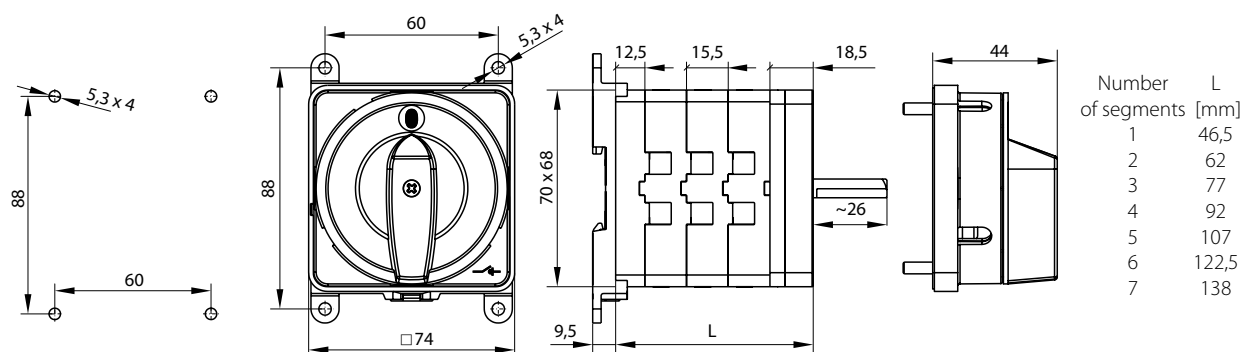

Number of segments in the switch

1 ... 7

Technical data

Rated insulation voltage U_e	690 V
Rated withstand impulse voltage U_{imp}	6 kV
Rated continuous current I_u	63 A
Rated operational current I_c	63 A
Conventional rated thermal current in the air I_{th}	63 A
Conventional rated thermal current in the enclosure I_{the}	63 A
Frequency	50/60 Hz
Rated operational current I_e for AC-21A, AC-22A	63 A (230/400/500/690 V)
Rated operational power P_e for AC-23A	15 kW (230 V) 28 kW (400 V) 34 kW (500 V) 46 kW (690 V)
Rated operational power P_e for AC-3	12 kW (230 V) 18 kW (400 V) 24 kW (500 V) 33 kW (690 V)
Switching angle	30°-45°-90°
Short-time short-circuit withstand current $I_{cw}(1s)$	1.2 kA
Rated short-circuit making current I_{cm}	0.7 kA
Wire gauge	6...16 mm ² (solid) 6...16 mm ² (stranded)
Panel mounting	□58
Screws in the terminals	M5
Tightening torque, wires (hold down)	2.0 Nm
Mechanical endurance	3.0 mln (transposition cycles)
Ambient temperature	-40 ... +70°C (work) -40 ... +70°C (storage)
Protection level: PN-EN 60529 to the panel	IP65
Protection level of OB enclosure	IP65
Protection level of the terminals	IP20
Pollution degree EN 60947-1	3
Protection class in OB housing	II
Vibration test (acc. to IEC 60068-2-6)	2...100 Hz (frequency) 13.2 Hz (frequency) ± 1 mm (acceleration amplitude) ±0.7 g (acceleration amplitude)
Shock test (acc. to IEC 60068-2-27)	15 g (peak acceleration) 11 ms (impulse duration)
Damp heat cyclic test (acc. to IEC 60068-2-30)	55°C (ambient temperature) 95% (relative humidity)
Salt mist cyclic test (acc. to IEC 60068-2-52)	severity 1