

## 12-module distribution board, surface mounted, IP65



### Technical data

$U_{max}$	AC 400V AC 1000V DC 1500V
$I_{max}$	63A
Version	1-row
VE/UK/PI	1 / - / 72
Material	PS / PC
Accessories	1x PE screw terminal (KN17PE) 1x cover strip (ADS12gr)
Number of modules	12
H x W x D	340 x 310 x 150
Sealing possible	Yes
Inlets	28x Ø5 - 12 mm 14x Ø5 - 15 mm 8x Ø6 - 20 mm 2x Ø8 - 26 mm 2x M32 / M50 2x M20 2x M25

### Accessories

Mounting brackets for mounting the NEPTUN switchgear

### Dimensions

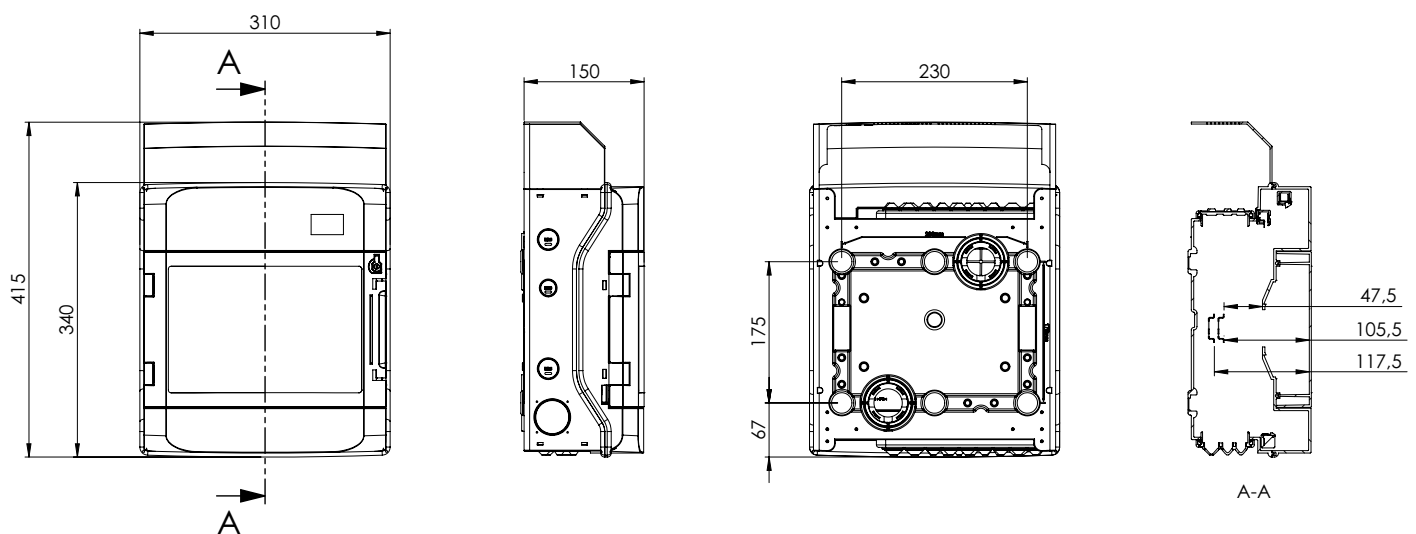

### Ordering code

**NEPTUN12EU**

### Product description

The new series of NEPTUN distribution boards for wet locations with their modern design is the best choice for all areas of application. They will work well in workshops, industrial halls, stables, garages and carports: The IP65 protection level ensures that the NEPTUN line meets all challenges and protects the product insides against the harmful ingress of water and dust. This protection is guaranteed in all sizes, from 1 to 4 rows. This is possible thanks to the continuous top and bottom sections closed by a high-quality transparent door. The door stop can be changed quickly and easily with the click system.

The distribution board series is equipped with a tool-free click system for positioning the mounting rails on 2 levels. The mounting rails can be quickly and easily moved from the standard mounting height of 50 mm to 62 mm. Thus, the NEPTUN line also offers sufficient space for the installation of larger rail-mounted devices and modular clamping systems.

The distribution board has through holes for M32 / M50 cable glands and side through holes for M20 and M25 in the upper and lower parts. The inlets at the top of the enclosure are already covered even without the use of a cable cover, thus ensuring an aesthetically pleasing appearance.

A technically advanced feature of the NEPTUN line is the IP65 membrane inlet flange, which allows cables to be introduced without the use of tools and without punching any through holes. This technology has the advantage that no additional components such as cable glands are required to comply with the IP65 protection class. A well-thought-out mounting system saves time and nerves. Therefore, the NEPTUN distribution board is equipped with elements such as an integrated level and marking of internal fixing points on the reverse side including dimensioning. NEPTUN distribution board external mounting brackets are available as accessories. Neptun can be used for rated insulation voltages AC 400V, AC 1000V and DC 1500V, which allows use in higher voltage photovoltaic systems. To ensure safe work conditions at AC 1000V or DC 1500V it is necessary to use external NAB mounting brackets.

Certificates: DIN EN 60670-1, DIN EN 60670-24